

Copyright © 2012 by Big Bike Parts, Inc. No part of this instruction sheet may be reproduced without the written permission of Big Bike Parts, Inc.

PART NO. 2-250**EXHAUST EXTENSION SET****HONDA GOLDWING GL1500 1988-1997**

11/19/2012

TOOLS NEEDED:	8MM WRENCH	12MM WRENCH (2X)	10MM WRENCH (2X)	HACK SAW	4MM (5/32") DRILL BIT & DRILL	FILE OR GRINDING TOOL
HARDWARE INCLUDED:	M6-1.0 X 25MM HEX HEAD BOLT (2X)		M6-1.0 HEX NUT (2X)		M6 LOCK WASHER (2X)	

NOTE: THREAD LOCK COMPOUND SHOULD BE USED ON ALL HARDWARE

PLEASE READ THROUGH AND UNDERSTAND THESE INSTRUCTIONS BEFORE BEGINNING.

SECTION ONE – REMOVING MUFFLERS

1. PLACE MOTORCYCLE ON CENTER STAND AND ALLOW TO COOL.
2. STARTING ON THE LEFT SIDE. REMOVE THE LOWER SIDE COVER (1B) LOCATED RIGHT BELOW THE PASSENGER FOOTRESTS (1C) BY REMOVING THE BOLTS (1A) WITH AN 8MM WRENCH. (SEE FIGURE 1)
3. USING A 12MM WRENCH LOOSEN BUT DO NOT REMOVE THE 2 BOLTS (2A) ON THE CLAMP AT THE FRONT OF THE MUFFLER. (SEE FIGURE 2)
4. USE TWO 12MM WRENCHES, ONE TO REMOVE THE BOLT (2C) AND THE OTHER TO HOLD THE NUT (2D) ON THE BACK SIDE. (SEE FIGURE 2)
5. ROTATE THE MUFFLER DOWN AND SLIDE IT TO THE REAR TO REMOVE IT.
6. REPEAT STEPS 2-5 AND REMOVE THE MUFFLER ON THE RIGHT SIDE.

SECTION TWO – MODIFY THE MUFFLERS

1. USING A 4MM (5/32") DRILL BIT DRILL THE CENTER OUT OF THE TWO RIVETS (3A) ON THE TOP AND BOTTOM OF BOTH MUFFLERS. (SEE FIGURE 3)
2. MEASURING FROM THE SEAM (3D) IN THE SMALL TAILPIPE MARK A LINE (3C) 13MM (1/2") ALL THE WAY AROUND THE PIPE. (SEE FIGURE 3)
3. USING A HACK SAW CUT ON THE LINE AND REMOVE THE ENDS OFF OF BOTH TAILPIPES.
4. USING A FILE OR A GRINDING TOOL REMOVE THE WELD FROM THE WELD POINT (3B) THAT IS HIGHER THAN THE SURFACE OF THE TAILPIPE.
5. DEBURR THE SHARP EDGES FROM THE CUTS AND TEST FIT THE EXHAUST EXTENSION.

SECTION THREE – INSTALL THE MUFFLERS AND EXTENDERS

1. REINSTALL THE MUFFLER BY REVERSING THE STEPS 3-5 IN SECTION 1.
2. SLIDE BOTH OF THE EXHAUST EXTENSIONS INTO PLACE ON THE MODIFIED MUFFLERS.
3. ALIGN BOTH EXHAUST EXTENSIONS SO THAT THEY ARE FACING THE DIRECTION THAT YOU WANT THEM.
4. INSERT THE M6-1.0 X 25MM HEX BOLT THROUGH THE TABS OF EACH EXHAUST EXTENSION AND PLACE THE LOCK WASHER AND NUT ON THE OPPOSITE SIDE.
5. TIGHTEN BOTH SIDES USING TWO 10MM WRENCHES UNTIL EXHAUST EXTENSIONS WILL NOT MOVE. DO NOT OVER TIGHTEN AND BEND TABS.
6. REINSTALL THE LOWER SIDE COVERS (1B) BY REVERSING STEP 2 FROM SECTION 1.

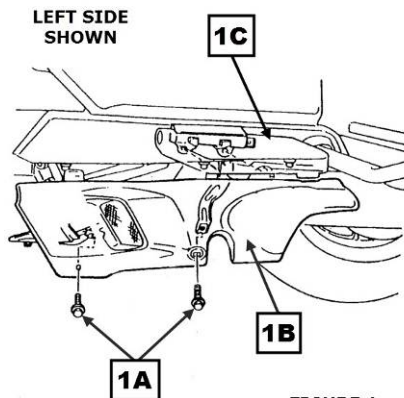

FIGURE 1

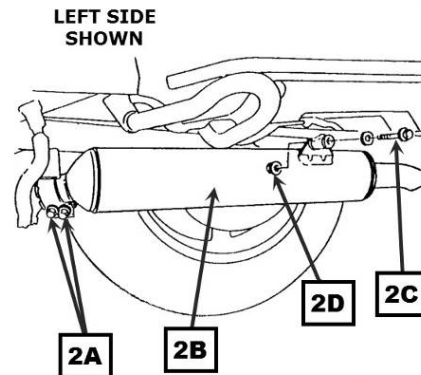

FIGURE 2

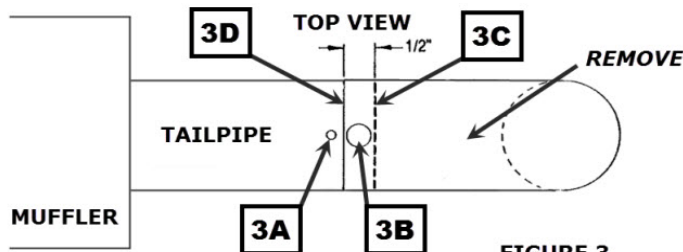

FIGURE 3

Scan code
with your
smartphone
to view
video

